

## HSK-A DIN 69893-1 FORM A

### TOOL HOLDERS

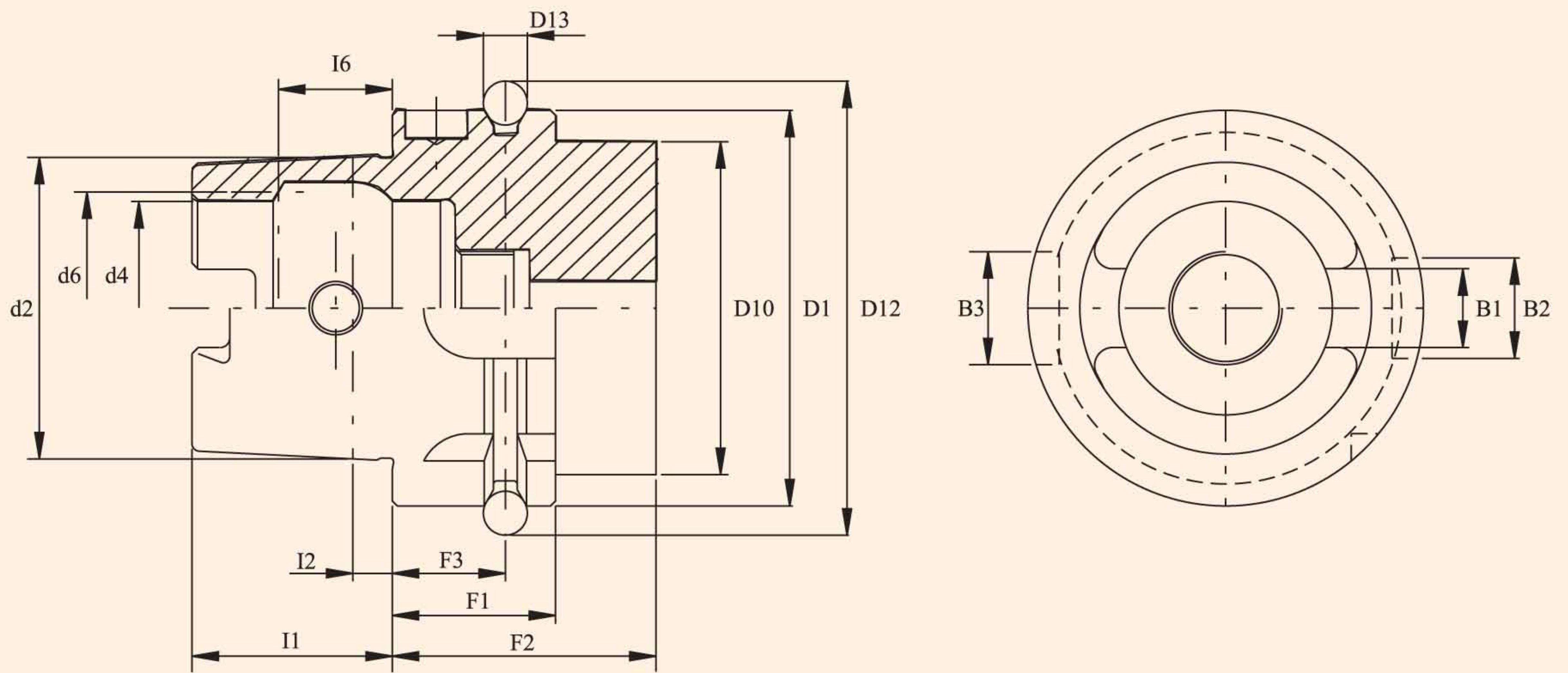

	HSK-A 50	HSK-A 63	HSK-A 100
b1	10,54	12,5	20.02
b2	12	16	20
b3	14	18	22
d1	50	63	100
d2	38	48	75
d4	26	34	53
d6	29	37	58
d10	42	53	88
d12	59,3	72,3	109,75
d13	7	7	7
f1	26	26	29
f2	42	42	45
f3	18	18	20
l1	25	32	50
L2	5	6,3	10
l6	14,13	118.13	28.56

All HSK Tool holders are manufactured according to DIN 69893-1 FORM A.  
Balanced to G 6.3 - 15,000 RPM.

Used on machining centres, milling machines turning machines, special machines with automatic tool change.

- ♦central, axial coolant supply through coolant tube.
  - ♦Torque transmission via two key slots at end of taper.
  - ♦Two slots on collar for tool magazine, location edge.
- Hole for data carrier DIN 69873 in collar.