

ADP120160 DEEP- Dot Peen Marking Machine

Marking area 120160mm | 4.7x6.3"



- **High quality extra deep markings**
- **Extremely durable and reliable**
- **COMPACT marking unit**
- **Easy automation with PLCs and Host Computers**
- **TTF, 2D codes, arcs and logos**
- **Unlimited range of stored marking programs**

System overview

ADP 120160 DEEP system marks permanently different materials in extra-depth, such as metals, aluminum, iron, cast, plastic... and many others, with a air driven and spring return pin. The characteristics of the message to be marked are easily programmed by software, such as height and width of the character, marking position in the window, the font, the parameters of work and communications and special fields. Two axes, X and Y each powered by a stepper motor, determine the movement of the pin and the fast and accurate position of the point in the marking window of the specific model.

The system consists of:

- Marking Head with cartridge, cable and pin
- Controller
- Filter
- Power supply

ADP 120160 DEEP - Dot Peen Marker

System Scheme

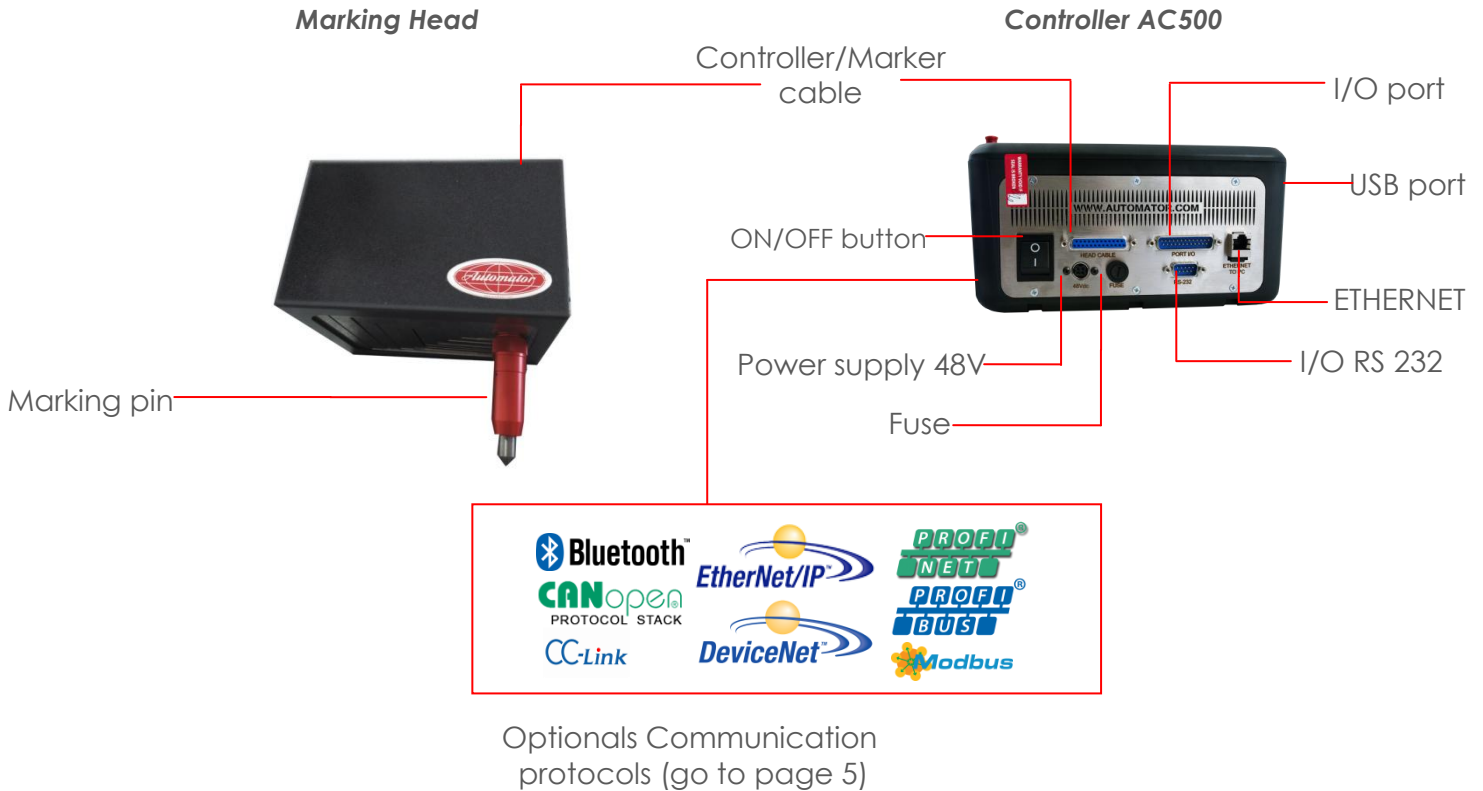

System Marking Modes

- Controlled dot deep marking** – The provided software allows the marking of font characters, (5x7, 11x16 etc..) where for each point the head activates the solenoid that moves the pin. Thanks to a specific parameter operating character, you can specify the density of points to be marked, typically expressed in dots / cm. The mode of the controlled point (dot) is recommended for marking of high quality and definition.

Marking Head

The ADP 120160 DEEP head has a marking area of 120x160mm (4.7x6.3 inches), using a pin that moves on X and Y axes with high precision. The shutter plates at the base of the cartridge protect the internal moving parts from dirt and waste. On the cover there are 4 holes for mounting the head in any orientation. The motor is bigger and stronger than any other ADP series machines, and allows the operator to mark extremely deep in the material.

Marking Head - Technical data

Overall dimensions: LxWxH (mm inches):	260x220x168 10.2x8.66x6.61
Weight (kg lbs):	6 13.25
Marking area (mm inches):	120 x 160 mm 4.72 x 6.30
Power supply (V):	100 – 240 VAC 50 – 60 Hz / 2 A
Air supply (Bar):	1 – 8 Bar
IP certification of the Cover:	IP54 (Equipped with protective rubber boot)
Working temperature (°C - °F):	0 – 50 °C 32 – 122 °F
Stock temperature (°C - °F):	-10 – 59 °C 14 – 138 °F
Humidity (%):	10% to 75% non-condensing
Cartridges available:	DOT12
Pins available	DOT12 (All Carbide)
Connectivity:	Power supply, ethernet port, USB port, RS 232/485, I/O

Marking head - Marker/Controller cable

Super flexible cable which connects the controller to the marking head. Available in different lengths.

Marking head - Marking speed

The speed depends on various factors, such as the font height, the marking depth, the desired quality and so on. With standards fonts height, the system can mark 3 characters per second.

Marking head - Marking depth

The depth of mark depends on the drive air pressure and on the material of the item to be marked. On aluminum with a thickness of about 1 mm | 0.40", a marking depth of 1 mm | 0,040". With thinner materials, the marking depth may increase. In cold rolled steel up to 0.5 mm (0.02") it's possible.

Marking head - Noise

When the marking system is set a 50% of its maximum level, its noise level has been measures at 74,6 dB (using the "time weighted average PPROACH (average sound exposure over an 8 hour period). Noise-level Tests have been carried out under controlled conditions, imitating as closely as possible industrial normal operations. Conditions such as the kind of surface to be marked, its shape and material, the rigidity of the working table and the ambient noise can alter the actual noise level.

Marking Head - Marking vibrations

Vibrations tests are referred to hand-arm (VM) and were performer under controlled conditions as closely as possible to standard industrial operations. Vibrations tests results: Steel marking surface 3 mm Pin MB 0,4m/s T(eav) >24H T(elv) >24H 6mm-Pin MB 0,8m/s T(eav) >24H T(elv) >24H Aluminum marking surface 3mm Pin MB 0,6m/s T(eav) >24H T(elv) >24H 6mm Pin MB 1,2m/s T(eav) >24H T(elv) >24H Conditions, such as the support, the rigidity of the work piece, the material and the setting of the machine can alter the actual vibration level.

ADP 120160 DEEP - Dot Peen Marker

Marking Head - Technical drawings

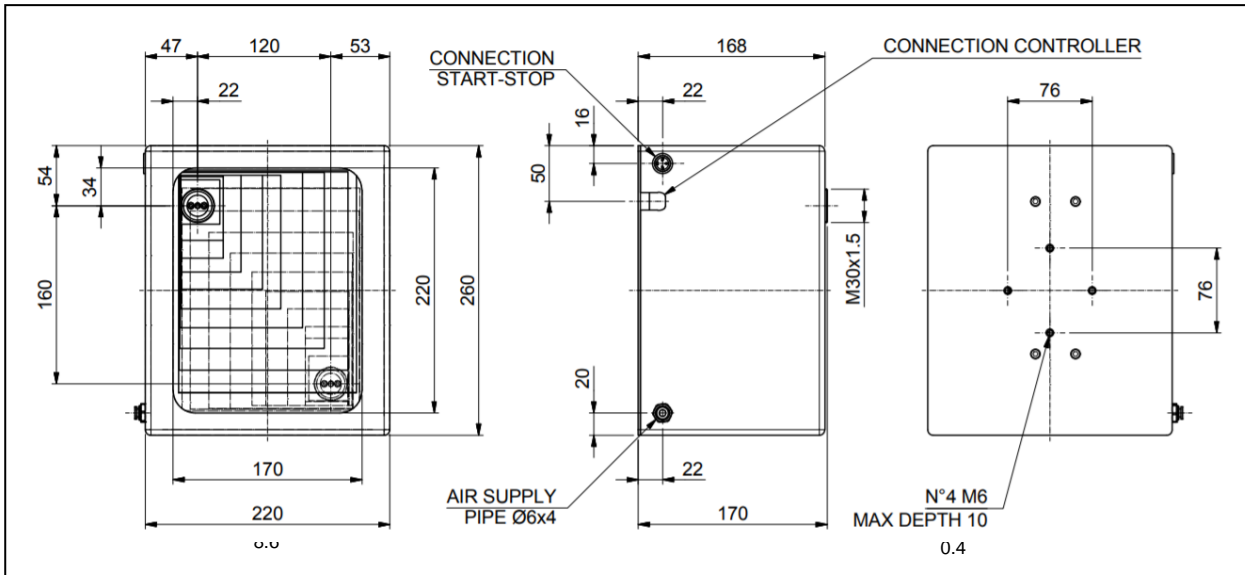

Marking Head - Available pins

Controlled (mm / inches)	<ul style="list-style-type: none"> • 12 mm – 0,70"
--------------------------	---

Universal Controller AC500

Controller AC500

The **Automator Universal Controller AC500**, with a 7" touch screen display, allows an easy and intuitive navigation in the software program, thanks to its stylus pen. Equipped with Serial port, USB interface and I / O connector, located on the rear, the controller is available in both bench and panel version for integrations.



Controller AC500 - Technical Data

Overall dimensions: LxWxH (mm inches):	220 x 260 x 125 mm / 8.7 x 10.2 x 4.9 "
Weight (kg lbs):	8.5 Kg / 19 lbs
Power supply (V):	100 – 240 VAC / 50 – 60 Hz / 2 A
Air supply (Bar):	1 – 8 Bar
IP certification of the Cover:	IP52
Working temperature (°C - °F):	0 – 50 °C / 32 – 122 °F
Stock temperature (°C - °F):	-10 – 59 °C / 14 – 138 °F
Humidity (%):	10% to 75% non-condensing
Connectivity:	RS232, RS485, Ethernet, Usb, I/O

Controller AC500 - External power supply

AC500 external power supply complies with the following directives:



Controller AC500 - Filter

Pressure regulator with filter for drive air

Controller AC500 - Technical Drawings

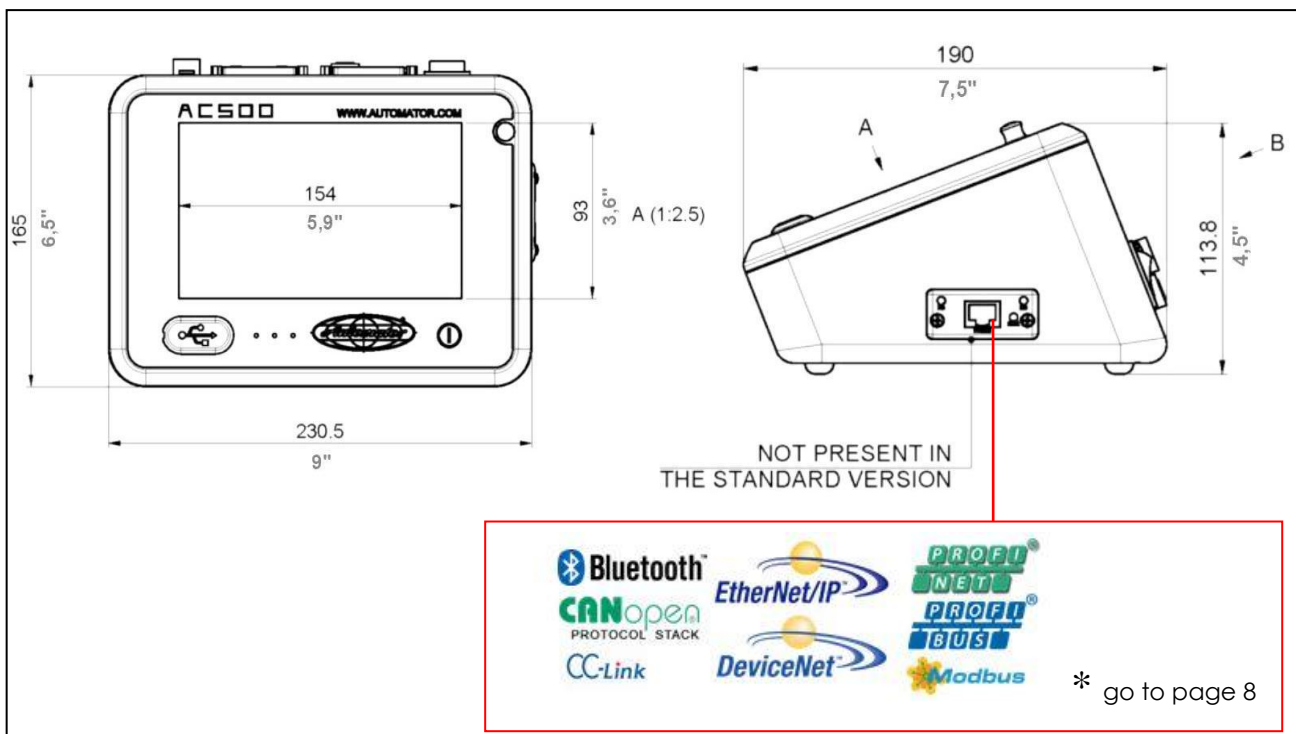

ADP 120160 DEEP - Dot Peen Marker

Controller AC500 - Scheme

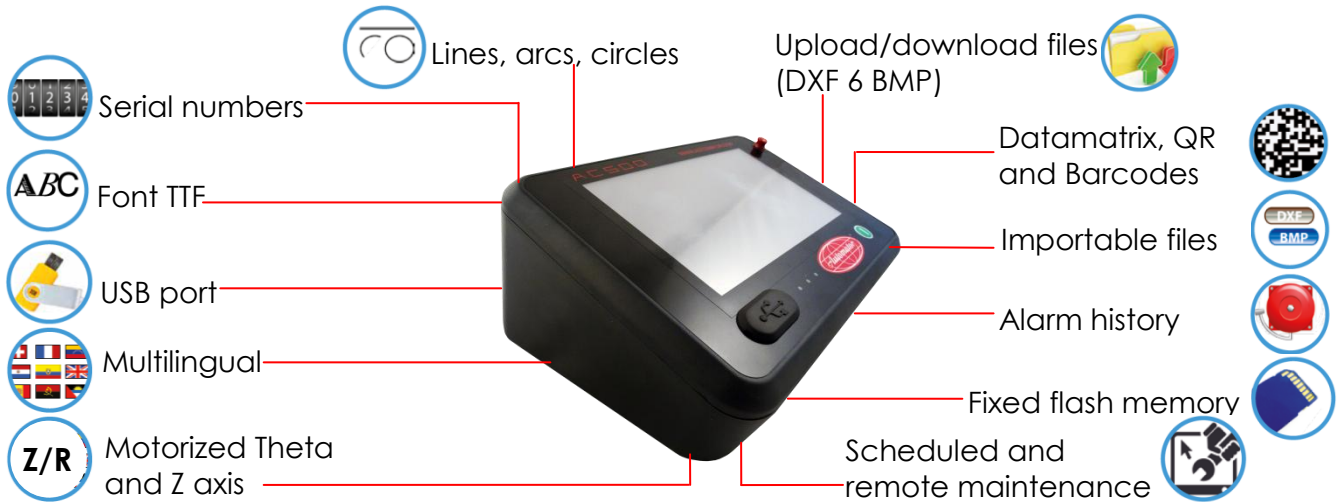

Controller AC500 - Optionals

- Bar Code Scanners and 2D Code Readers
- Foot Start/stop button
- Logo and font generator software

WARNING

Do not block air vents on the side of the case. The marking system must be electrically isolated from any other device that may generate electromagnetic interference.

Universal Controller Software

The AC500 coupled with our Automator software allows an intuitive user interface with absolute graphic flexibility. Thanks to the touch screen graphic display, it is easy to navigate and to create messages to be marked and parameters.

The preview allows to represent exactly what will be marked and any change in the message will be displayed instantly. The software provides for the creation of messages with the date in various formats, fix or variable texts, codes, serial numbers, Datamatrix and logos. Possible the creation of the programs on the PC (running Windows operating systems), which can be easily transferred to the AC500 controller with USB stick or USB connection.



Host Communications

The AC500 software allows you to set the communication parameters to share data with a host computer, supporting RS-232 and RS-485 serial communication protocols and Ethernet TCP/IP interface. The software provides two different communication protocol modes:

- Programmable Protocol
- Extended Protocol

The serial RS-232 communications interface is available for remote devices: host computers, terminals, or scanners/readers.

The Ethernet (TCP/IP) interface is available for host computers working over a LAN (Local Area Network).

The RS-485 interface is available for multi-drop networks or long transmission distances or of up to 31 AC500 controllers.

Programmable Protocol

The programmable protocol is available for QR, barcodes and Datamatrix readers:

- no error checking or alarm/messages about data to be marked
- Starting character defines where the software begins to count character positions
- Terminating Character defines the end of the data to be read
- Character Position counted from the starting character independently by all the previous characters
- Variable length messages available

Extended Protocol

The extended protocol is bidirectional and available for marking applications that need serial communications. It includes error checking/alarm and a range of transmission messages Types: SOH, TYPE, [##] , STX, [DATA], ETX, BCC, CR

- SOH (ASCII) - The AC500 controller ignores all characters received before the SOH.
- TYPE (printable ASCII character) - It defines the types and content of the message from the host

Type 1 - It overwrites a field in the loaded marking with data from the Host.

Type P - It specifies the marking name to be loaded

Type Q - It updates the marking to be printed with new infos from the host to be placed in the Query table

Type V - It updates the variable text in a field of the current marking with infos from the Host.

Type O - It sends the marker to the online position

Type G - It sends a start print command for the current marking program

Type I - It returns a status hexadecimal code

- [##] - It specifies the Station ID of the AC500 for multi-drop network applications (Range: 00-31)

ADP 120160 DEEP - Dot Peen Marker

- STX (ASCII Start of Text Character: 002H)
- ETX – (ASCII text ending character: 003H)
- [DATA] - Optional character string for message types like Type 1, P, Q, and V
- BCC - Optional Block Check Code to improve link reliability by providing fault detection

Configurations

In addition with the production lines integration mode, ADP 120160 can be set on a toolstand for workstation marking applications

Benchtop configuration

Aluminum toolstand with Z axis adjustment knob adjustable for the surface to be marked.

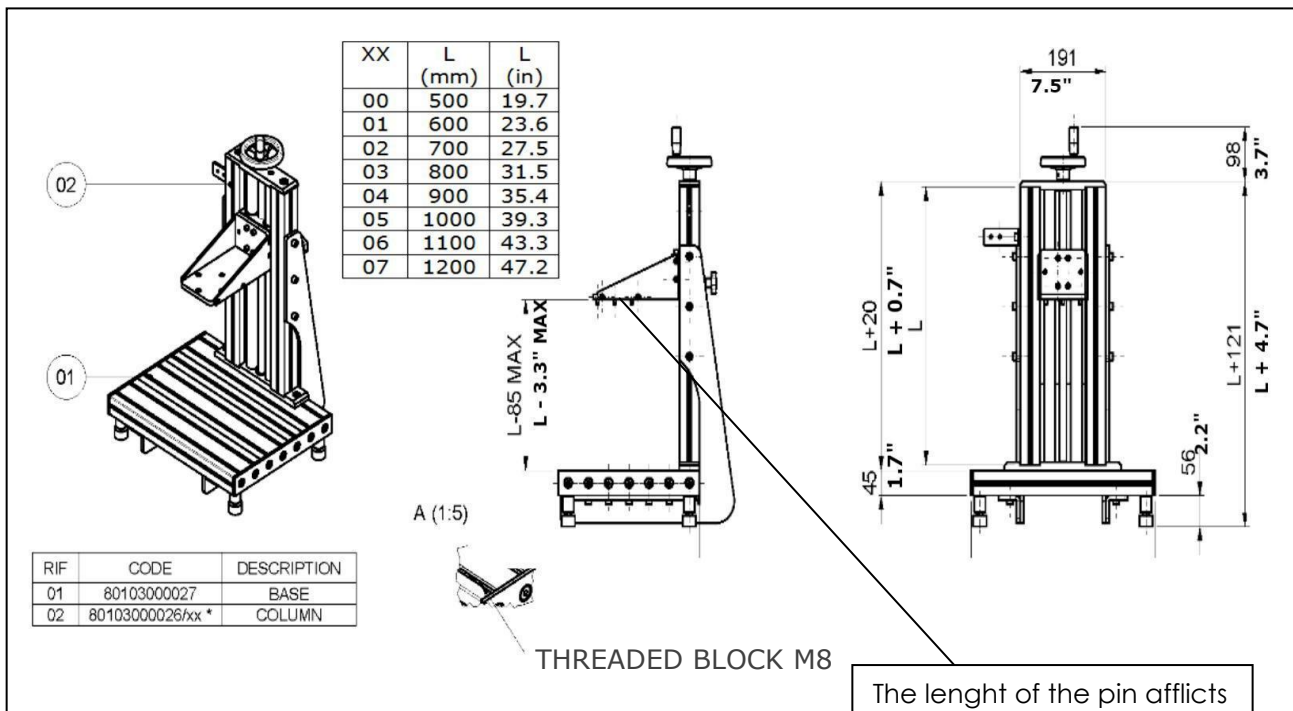

*TRADEMARKS

Automator, ADP and AC500 are registered trademarks of Automator International Srl.

Windows is a registered trademarks of Microsoft Corporation

Bluetooth is a registered trademark of Bluetooth SIG, Inc.

CanOpen is a registered trademark of CAN in Automation Inc

CCLink is a registered trademark of Mitsubishi Inc.

Ethernet/IP and DeviceNet are registered trademarks of Rockwell Automation.

ProfiNet and ProfiBus are registered trademarks of Profibus Inc.

ModBus is a registered trademark of Schneider Automation